

1 2 3 4 5 6

A

A

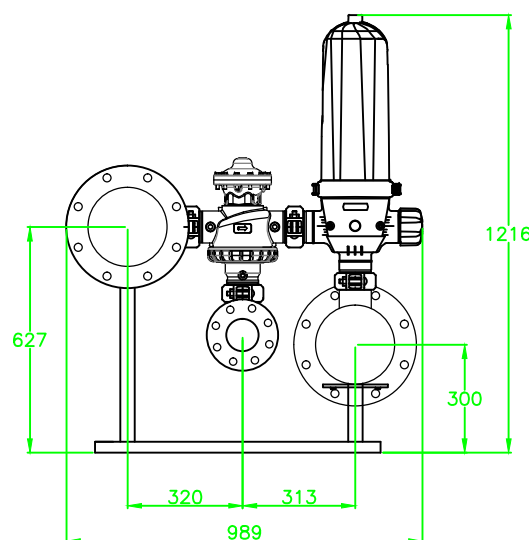
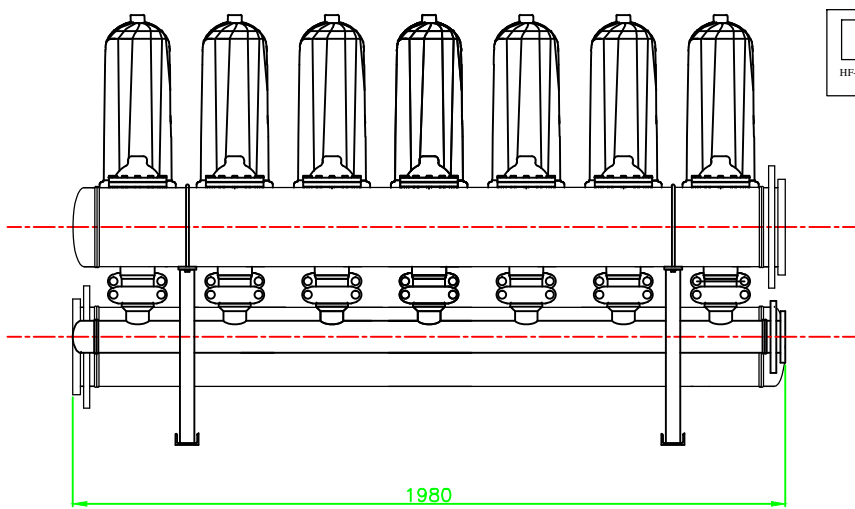

B

B

C

C

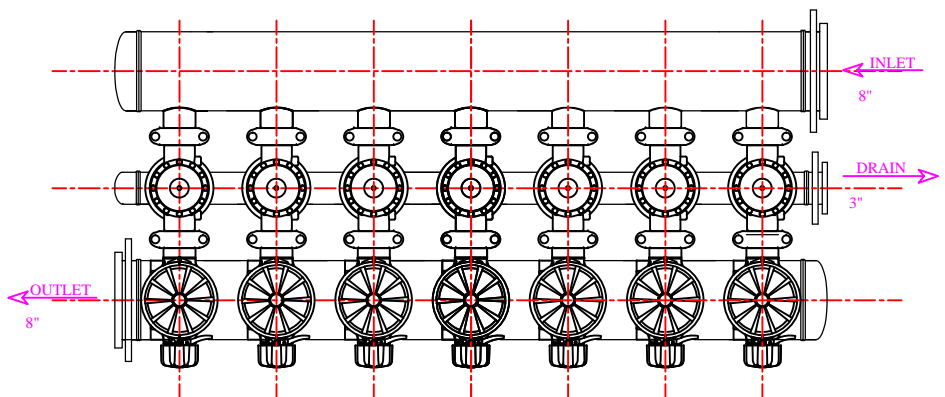

NOTES:

1. PIPING MATERIAL: PE, Carbon steel st, 304.
2. CONNECTION TYPE: ANSI 150# FLANGE.
3. MANUAL VALVES SHALL BE INSTALLED AT THE INLET AND OUTLET OF THE DISC FILTER.
4. THE DRAIN PIPE SHALL BE CONNECTED TO THE DRAINAGE SYSTEM.
5. POWER SUPPLY: 220V/1PHASE/50HZ.
6. CONCRETE FOUNDATION (HEIGHT: 200MM)
7. AND EXPANSION ANCHOR BOLTS ARE SUGGESTED FOR SITE INSTALLATION.

D

D

1 2 3 4 5 6

							Beijing Haiiao Technologies Co.,Ltd				
标记	处数	分区	更改文件号	签名	DATE		HF-A3-7-8 DISCFILTER	MATERIAL	QUANTITY	WEIGHT	SCALE
R	内部评审版						DWG NO	/	1		1:1
A	初步设计						HF-A03-7-00-01	SHEET		OF	
REV	DESCRIPTION	DESD	DATE	APPD	DATE	APPD	DATE				