

Model	Height	Vol	Weight
3087-4T4B	2150 mm	728L	

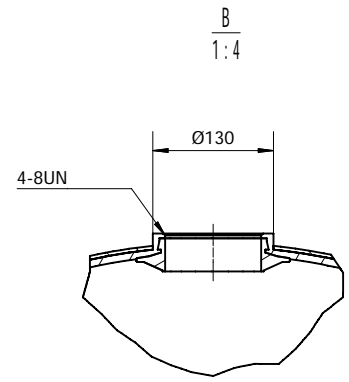

- NOTES:**
1. Inner shell - Polyethylene (PE) seamless one-piece tank liner
  2. Outer shell - Continuous strands of fiber-glass with high strength epoxy resin
  3. Bottom base - FRP reinforced tripod base
  4. Opening - 4 inch thread opening
  5. Tanks meet all applicable specification of NSF/ANSI 044 standard
  6. Operating Specifications:
    - Maximum Working Pressure : 150 PSI (1.0MPA)
    - Temperature :1-49 C (34-120 F )
    - Maximum Vacuum:127mm Hg(5"Hg)
  7. Liner inspection
    - No more than 20 internal 、 external blemishes、 burnt debris
    - No internal 、 external blemishes、 burnt debris larger than 5 \*5 mm
  8. Surface finish
  9. Surface to be free of resin, glass,nicks,barbed filament
  10. Tank to be bonded to base
  11. The base to be level correction
  12. Top and bottom opening to be parallel,top opening to be parallel with the base

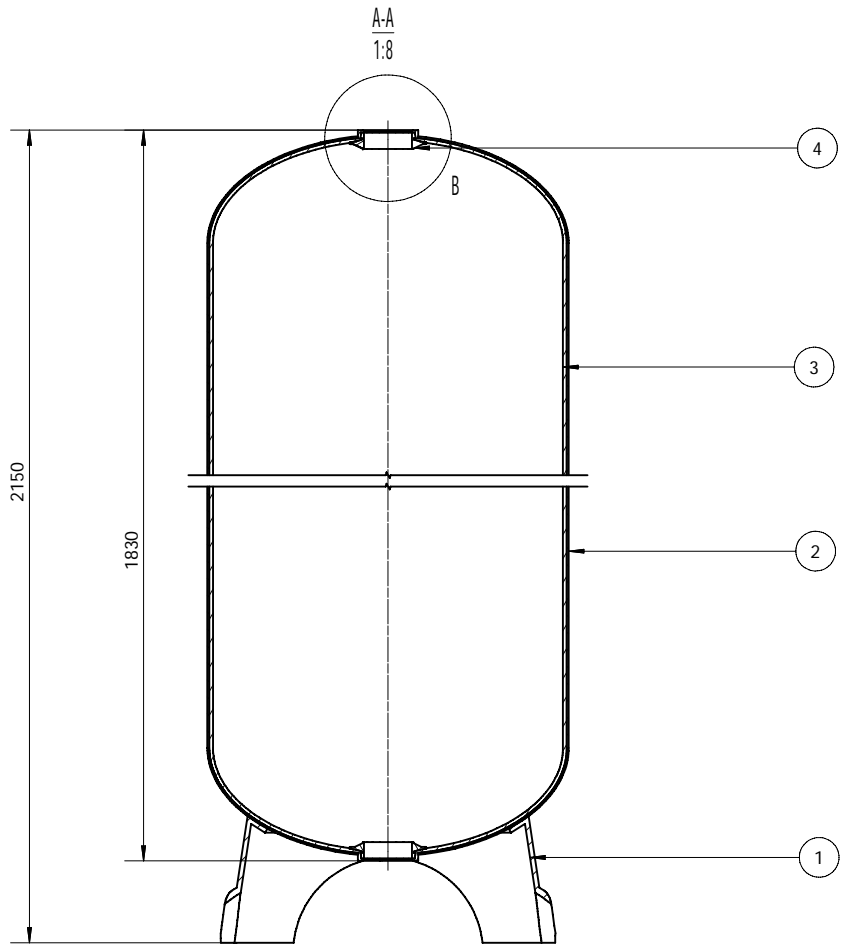
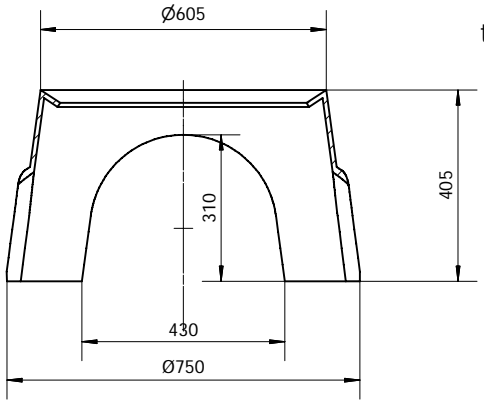
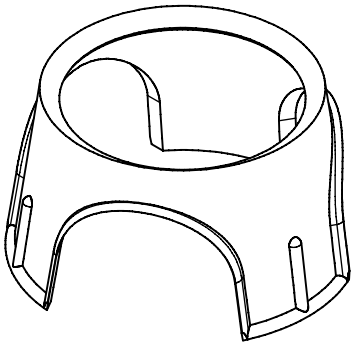

C-C  
1:8

4	Thread	2	LLDPE	
3	Liner	1	PE	
2	Outer sheel	1	FRP	
1	Base	1	FRP	
项目	名称	数量	材料	注释

江苏开能华宇环保设备有限公司					
标记	处数	分区	更改文件号	签名	日期
设计	张新华	2014/3/4	标准化		
审核					
工艺			批准		
阶段标记			重量(Kg)	比例	3072H-4T4B
本图尺寸均以mm计，图中尺寸请勿量取。					